

DE LA RUE
CASH SYSTEMS



DeLaRue

MACH[®] 9

Coin Sorter/Counter

Fast, accurate coin processing for high volume applications



Available with
Enhanced Coin Detection
(CDE)

MACH[®] 9

Coin Sorter/Counter

The De La Rue **Mach 9** is an enhanced coin sorter/counter with an enhanced coin detection option suitable for stand-alone applications where high volume coin processing is needed.

Fast, Efficient and Reliable

Featuring a processing speed of up to 4,500 coins per minute, the De La Rue **MACH 9** is one of the fastest coin sorters/counters available in its class. The **MACH 9** is capable of sorting up to nine denominations of coin. With its large tilting inspection pan, holding up to 5,000 coins, coupled with the unique auto-feed system, the **MACH 9** enhances productivity through efficient coin processing.

Easy to Use

Giving users the ability to easily change settings to meet their individual needs, selectable bag stops, batch and grand totals are accessed via a direct keypad. A two-line alphanumeric display conveys relevant operations messages at a glance. Full travel keys enable easy and quick data entry. With few moving parts and simplified electronics, the **MACH 9** is easy to maintain.

Ergonomic Design

The **MACH 9**'s ergonomic design is both functional and aesthetically pleasing, allowing the unit to fit into virtually any work environment.

Technical Specification

Coin size range

Diameter: .61" to 1.51" (15.5mm to 38.3mm)
Thickness: .04" to 0.12" (1.0mm to 3.0mm)
Differential: .02" (0.5mm) minimum

Inspection pan capacity

Up to 5,000 coins

Coin feeder capacity

Up to 10,000 coins

Processing speed

Up to 4,500 coins per minute

Sorting capability

Up to 9 different denominations

Bag stops

Fully adjustable

Security features

Lock out security to protect operating information
Battery back up in the event of power failure.

Power supply

90- 264 VAC (±10%), 50/60 Hz

Standard features

Four RS232 serial interface ports

Options

High speed printer for audit trail
Remote batch total display
Security doors
Currency counter interface
Magnet kit
MICS control - includes:
3 levels of totals with programmable ID numbers, user programmable bag stops, media register for positive and negative inputs and up to 200 separate identifiers for teller/product totals
Enhanced Coin Detection to serve as an aid in detection of foreign, bent and damaged coin

Dimensions

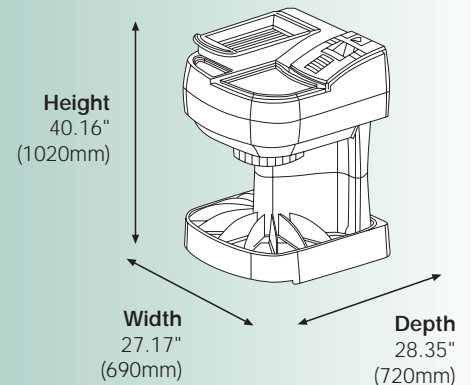

Weight

198.5 lbs (90.0kg)



Enhanced Coin Detection (CDE)

With the addition of the Enhanced Coin Detection (CDE) option, De La Rue's Coin Signature Detection System (CSDS[™]) provides an aid to detect and reject counterfeit and foreign coins.

Multiple Functionality and Options

The **MACH 9** is easily adaptable to any high volume application. The Management Information Control System (MICS) option provides three levels of memory and allows other media to be entered, such as checks and rolled coin and notes, thus ensuring a comprehensive audit trail.

Featuring four RS232 serial ports fitted as standard, the **MACH 9** can interface to other cash settlement systems and peripheral equipment, such as currency counters, enabling complete cash reconciliation.

De La Rue Cash Systems coin and currency processing products are the direct result of over 100 years experience in the design, manufacturing and distribution of world class cash handling solutions. Worldwide service and support is provided through De La Rue Cash Systems' network of branch offices and authorized distributors.



BS EN ISO 9001
FM 689



This leaflet is for general guidance only. De La Rue International Limited is pleased to give detailed specifications of its products in this leaflet. As the company's products and services are continually being developed it is important for customers to check that the information contained herein includes the latest particulars. This document is not part of a contract or license save insofar as may be expressly agreed.

Copyright © De La Rue Cash Systems Inc.
De La Rue and the Founders Head Device is a registered trademark of De La Rue plc
MACH is a registered trademark of De La Rue Inc.
CSDS is a trademark of De La Rue Inc.

DE LA RUE CASH SYSTEMS

2441 Warrenville Rd.
Lisle, IL 60532
Telephone: (800) 527-2638
Fax: (630) 577-1270
Web: www.delarue.com

